**User's
Manual**

**701930
Current Probe**

Foreword

Thank you for purchasing the Current Probe (Model 701930).

This instruction manual contains useful information about the instrument's functions and operating procedures as well as precautions that should be observed during use. To ensure proper use of the instrument, please read this manual thoroughly before beginning operation.

After reading the manual, keep it in a convenient location for quick reference whenever a question arises during operation.

Revisions

1st Edition: June, 2001

2nd Edition: November, 2005

The following symbols are used in this manual to alert you to important information.



Affixed to the instrument. Indicates danger to personnel or instrument and the operator must refer to the User's Manual. The symbol is used in the User's Manual to indicate the reference.

WARNING

Describes precautions that should be observed to prevent serious injury or death to the user.

CAUTION

Describes precautions that should be observed to prevent minor or moderate injury, or damage to the instrument.

Note

Provides important information for the proper operation of the instrument.

Checking the Contents of the Package

If the wrong instrument or accessories have been delivered, or if some accessories are missing or defective, contact the dealer from which you purchased them.

Current Probe (Model 701930) Main Body

Accessories

- One user's manual (this document).
- Carrying case

Safety Precautions

This probe meets the Measurement Category II and III, and Pollution Degree 2 requirements as given in the IEC-61010-1 standards.

The following general safety precautions must be observed during all phases of operation, service, and repair of this instrument. If this instrument is used in a manner not specified in this manual, the protection provided by this instrument may be impaired. Also, Yokogawa Electric Corporation assumes no liability for the customer's failure to comply with these requirements.

The following symbols are used on this instrument.



To avoid injury, death of personnel or damage to the instrument, the operator must refer to an explanation in the User's Manual or Service Manual.



Both direct and alternating current.



Do not apply around or remove from HAZARDOUS LIVE conductors.

Precautions

In order to ensure safe operation and to obtain maximum performance from the unit, observe the cautions listed below.

WARNING

- To avoid short circuits and accidents that could result in injury or death, use this current probe only with power lines carrying 600 V or less (CATII), or 300 V or less (CATIII).
- Also to avoid short circuits and personal injury when the clamp is open or measurement is being performed, do not apply the clamp to any bare conductors.
- When applying the clamp or taking measurements, don't touch the clamp anywhere from the edge of the barrier up to the conductor being measured.
- Be careful not to damage the insulation surface while taking measurements.
- This instrument is made for use with the Power Supply (Model 700938 or 701934). It is possible to use a power supply other than the 700938 or 701934, provided that the connector and pin assignments match, and that voltage and other electrical specifications are satisfied. Regardless of which power supply is used, for safety, make sure that it has a protective earthing with double-insulation construction.
- Make sure that the waveform measuring equipment connected to this unit's output terminal (BNC) is equipped with a power supply having a protective earthing with double-insulation construction.
- If the waveform measuring instrument connected to this unit's output terminal (BNC) is equipped with any other input terminal, take the following precautions to ensure that the other instrument does not form a bridge between the probe and any hazardous live parts.
 - 1 Isolate the terminal to which the probe is connected from other terminals on the measuring instrument using basic insulation conforming to the overvoltage category, working voltage, and pollution degree requirements of the circuit being tested.
 - 2 If basic insulation requirements cannot be met between the terminal to which this unit is connected and other terminals of the measuring instrument, make sure that the voltage input to the measurement terminal does not exceed the safe voltage level(SELV-E)*.
 - 3 Make sure to ground the measuring instrument.
 - 4 Beware of electric shock when connecting the probe to the item being measured. Do not remove the probe from the instrument while the probe is connected to the item.
 - 5 Before connecting the probe, check that the measuring instrument and power supply are properly grounded and that the output connector and power plug are connected to the BNC connector and power receptacle, respectively.
 - 6 Read and observe all warnings and precautions relating to electrical safety for the measuring instrument being connected to the probe.
Refer to the following standards regarding the meanings of underlined terms.
IEC61010-1
IEC61010-2-031
IEC61010-2-032
- To prevent electric shock, do not allow the unit to become wet and do not use the unit when your hands are wet.

* Do not exceed the following levels: 30 Vrms, 42.4 Vpeak, and 60 VDC.

CAUTION

- Do not subject the unit to vibrations or shocks during transport or handling. Be especially careful to avoid dropping the unit.
- Do not store or operate the unit where it will be exposed to direct sunlight, high temperature, high humidity, or condensation. If exposed to such conditions, the unit may become damaged, the insulation may deteriorate, and the unit may no longer satisfy its specifications.
- Before using the unit, inspect it and check the operation to make sure that it was not damaged due to poor storage or transport conditions. If damage is found, contact your dealer or YOKOGAWA representative.
- This instrument is not waterproof or dustproof. Do not use the unit in a wet or dusty environment.
- The sensor head is a precision assembly including a molded component, a ferrite core, and a Hall effect element. It may be damaged if subjected to sudden changes in ambient temperature, or mechanical strain or shock, and therefore great care should be exercised in handling it.
- The matching surfaces of the sensor head are precision ground, and should be treated with care. If these surfaces are scratched, performance may be impaired.
- If there is any type of dust or dirt on the matching surfaces of the sensor head, measurements may be affected. Wipe it away gently with a soft cloth.
- In order to avoid damaging the sensor cables do not bend or pull the sensor cable or power supply cable.
- Gently wipe dirt from the surface of the unit with a soft cloth moistened with a small amount of water or mild detergent. Do not try to clean the unit using cleaners containing organic solvents such as benzene, alcohol, acetone, ether, ketones, thinners, or gasoline. They may cause discoloration or damage.
- When the power is ON, keep the core section of the sensor closed, except when clamping it onto the conductor to be measured. The facing surface of the core section can be scratched while it is open.

Note

Accurate measurement may be impossible in locations subject to strong external magnetic fields, such as near transformers and high-current conductors, or in locations subject to strong external electric fields, such as near radio transmission equipment.

Contents

1

2

Foreword	i
Checking the Contents of the Package	ii
Safety Precautions	iii

Chapter 1 701930 Current Probe

Product Overview	1-1
Features	1-1
Names of Parts	1-2
Description of Parts	1-3
1 Clamp	1-3
2 Clamp Lever	1-3
3 Clamp Lock	1-3
4 Sensor Head	1-3
5 Barrier	1-3
6 Demagnetizing Switch (DEMAG)	1-3
7 Zero Adjustment Dial (ZERO ADJ)	1-3
8 Output Connector	1-3
9 Power Plug	1-3
Measurement Procedure	1-4
Notes on Use	1-4
Preparations for Measurement	1-5
Demagnetizing and Zero Adjustment	1-6
Measurement Procedure	1-7
Specifications	1-9
Product Specifications	1-9
Applicable Standards	1-10

Chapter 2 Malfunction? First, Investigate.

Corrective Action to be Taken in Case of an Abnormality	2-1
---	-----

Chapter 1 701930 Current Probe

Product Overview

This unit can be directly connected to a BNC input connector of a waveform measuring instrument such as a digital oscilloscope or a DL Series instrument, and by clamping it to a conductor to be measured, allows the current waveform to be easily captured.

Features

- Highly accurate current detection
- Easy current measurement
- Wideband frequency characteristics; DC to 10 MHz
- Wide clamp permits measurement of high current levels
- Easy protect function during excessive input

Names of Parts

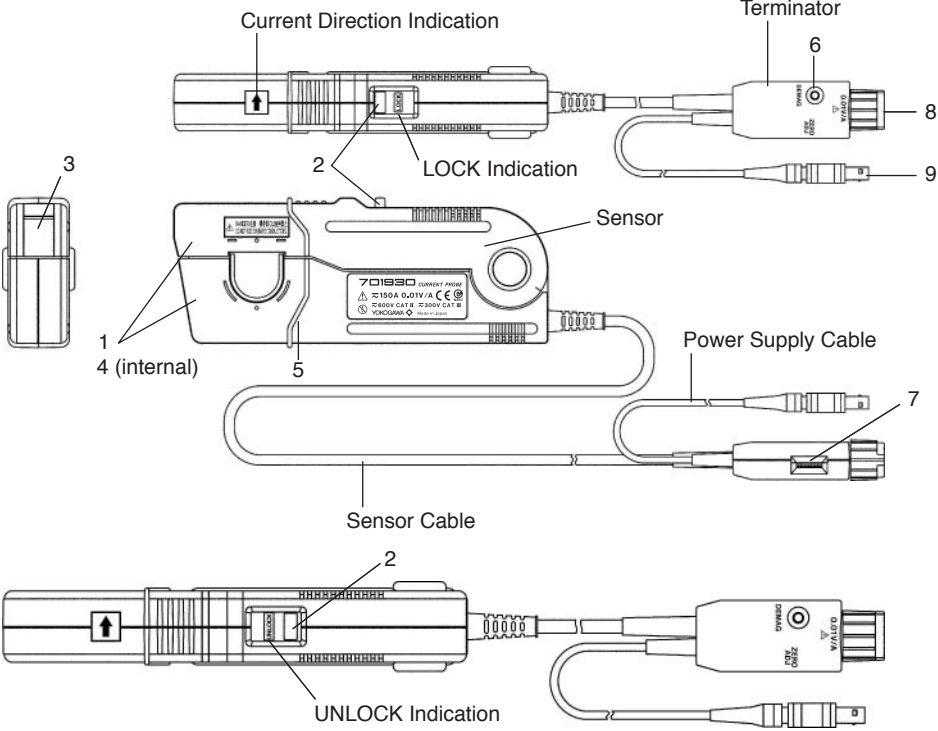

Description of Parts

1 Clamp

The part which clamps to the conductor to be measured.

2 Clamp Lever

The lever for opening and closing the clamp. Make sure to open or close the clamp only by using the clamp lever.

3 Clamp Lock

Locks the clamp in place when it is closed.

4 Sensor Head

This clamps the conductor being measured, and carries out the actual current measurement. It is a precision assembly including a molded component, a ferrite core, and a Hall effect element. It may be damaged if subjected to sudden changes in ambient temperature, or mechanical strain or shock, and therefore great care should be exercised in handling it.

5 Barrier

A piece which indicates the limit up to which the user may safely touch the clamp, and reduces the danger of touching the conductor during testing. Do not touch any part of the clamp beyond the barrier during measurement.

6 Demagnetizing Switch (DEMAG)

If the core has been magnetized by switching the power ON and OFF, or by an excessive input, this switch demagnetizes it. Always carry out demagnetizing before measurement. The demagnetizing process takes about three seconds. During demagnetizing, a demagnetizing waveform is output.

7 Zero Adjustment Dial (ZERO ADJ)

Use the zero adjustment dial to correct for the effect of a voltage offset or temperature drift on the unit. When performing measurements, always carry out a zero adjustment after demagnetizing.

8 Output Connector

The current waveform of the measured conductor is output at a constant rate (0.01 VA in conjunction with the waveform measuring instrument with an input impedance of 1 M Ω .)

Connect to the BNC input connector of the waveform measuring instrument.

Note

- The output of this unit is terminated internally. Use a high-impedance input to the measuring instrument. With an input impedance of 50 Ω , accurate measurement is not possible.
 - If using BNC-banana plug or similar adapters to connect to input terminals other than BNC connectors, make sure the polarity is correct.
 - Turn the clamp lever until it clicks, and check that it is locked securely.
-

9 Power Plug

Connect the power plug to the receptacle on the Power Supply (Model 70938 or 701934) to supply power to the sensor and terminator.

Measurement Procedure

Notes on Use



WARNING

- To avoid short circuits and accidents that could result in injury or death, use this current probe only with power lines carrying 600 V or less (CATII), or 300 V or less (CATIII).
- Also to avoid short circuits and personal injury when the clamp is open or measurement is being performed, do not apply the clamp to any bare conductors.
- When applying the clamping or taking measurements, don't touch the clamp anywhere from the edge of the barrier up to the conductor being measured.
- Be careful not to damage the insulation surface of the conductor being measured while taking measurements.
- This instrument is made for use with the Power Supply (Model 700938 or 701934). It is possible to use a power supply other than the 700938 and 701934, provided that the connector and pin assignments match, and that voltage and other electrical specifications are satisfied. Regardless of which power supply is used, for safety, make sure that it has a protective earthing with double-insulation construction.
- Make sure that the waveform measuring equipment connected to this unit's output terminal (BNC) is equipped with a power supply having a protective earthing with double-insulation construction.
- If the waveform measuring instrument, which is connected to this unit's output terminal (BNC) is equipped with any other input terminal, take the following precautions to ensure that the other instrument does not form a bridge between the probe and any hazardous live parts.
 - 1 Isolate the terminal to which the probe is connected from other terminals on the measuring instrument using basic insulation conforming to the overvoltage category, working voltage, and pollution degree requirements of the circuit being tested.
 - 2 If basic insulation requirements cannot be met between the terminal to which this unit is connected and other terminals of the measuring instrument, make sure that the voltage input to the measurement terminal does not exceed the safe voltage level(SELV-E)*.
 - 3 Make sure to ground the measuring instrument.
 - 4 Beware of electric shock when connecting the probe to the item being measured. Do not remove the probe from the instrument while the probe is connected to the item.
 - 5 Before connecting the probe, check that the measuring instrument and power supply are properly grounded and that the output connector and power plug are connected to the BNC connector and power receptacle, respectively.
 - 6 Read and observe all warnings and precautions relating to electrical safety for the measuring instrument being connected to the probe.
Refer to the following standards regarding the meanings of underlined terms.
IEC61010-1
IEC61010-2-031
IEC61010-2-032
- To prevent electric shock, do not allow the unit to become wet and do not use the unit when your hands are wet.

* Do not exceed the following levels: 30 Vrms, 42.4 Vpeak, and 60 VDC.

Preparations for Measurement



CAUTION

- Before turning ON the power, make sure that the voltage of the power supply being used matches the supply voltage indicated on the rear panel of the 700938 or 701934.
- When using the Current Probe (Model 701930), you can only connect as many active probes simultaneously to the Power Supply (Model 700938 or 701934) or the DL Series rear panel probe power supply connector as allowed depending on the current value of the conductor.

The current consumption of the Current Probe (Model 701930) is dependent upon the measured current value. Do not let each active probe's total current consumption exceed the current regulated by the Power Supply (Model 700938) or the DL Series rear panel probe power supply connector (see figure below).

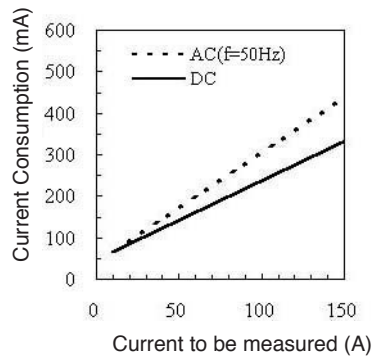

Current consumption* vs. current to be measured (typical) □

* The sum total of a positive and negative current consumption.

1. Have the Power Supply (Model 700938 or 701934), and oscilloscope or recorder for waveform measurement ready.
2. Turn the power switch **OFF** and connect the power cord.
3. Connect the power plug of the 701930 to the power receptacle of the 700938 or 701934.
4. Turn the 700938 or 701934 power switch **ON**, and check that the front panel power indicator lights.

Note

The output of this unit is terminated internally. Use a high-impedance input to the measuring instrument. With an input impedance of 50 Ω , accurate measurement is not possible. When power is supplied to the 701930, a demagnetizing waveform might be generated.

Demagnetizing and Zero Adjustment



CAUTION

- When disconnecting the output connector, be sure to release the lock before pulling the connector. Forcibly pulling the connector without releasing the lock, or pulling on the cable will result in damage to the terminator.
 - If using BNC-banana plug or similar adapters to connect to input terminals other than BNC connectors, make sure the polarity is correct.
 - Do not demagnetize when the clamp is connected to a conductor. Doing so might damage the components of the circuit being measured.
 - Do not begin supplying power to the 701930 after the clamp has been connected to a conductor. Doing so might damage the components of the circuit being measured.
-

1. With the waveform measurement instrument input at ground, adjust the trace to the zero position.
2. Set the input coupling of the waveform measurement instrument to DC.
3. Connect the output connector of the 701930 to the input connector of the waveform measurement instrument. Turn the clamp lever until it clicks, and check that it is locked securely.

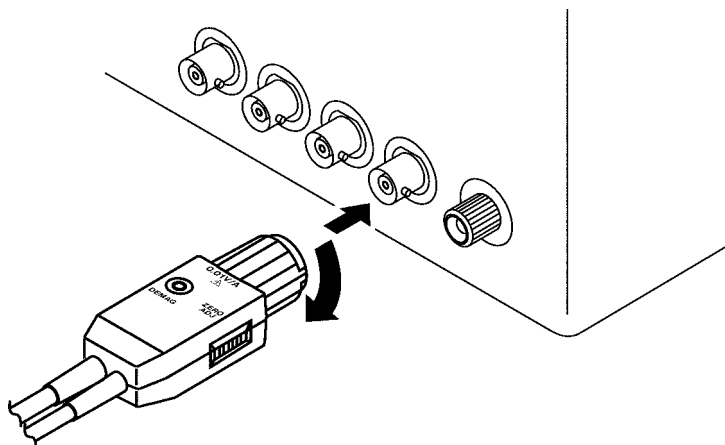

4. Without clamping the conductor to be measured, press the clamp lever until the **LOCK** indication appears (and the **UNLOCK** indication disappears), and then check that the clamp is properly closed.
5. Press the demagnetizing switch (**DEMAG**) on the terminator.
6. Turn the zero adjustment dial on the terminator to adjust the trace to the zero position.

Note

The output of this unit is terminated internally. Use a high-impedance input to the measuring instrument. With an input impedance of 50 Ω , accurate measurement is not possible.

Measurement Procedure



CAUTION

- The maximum continuous input range is based on heat that is internally generated during measurement. Never input current in excess of this level. Doing so may result in damage to the probe.
- The maximum continuous input range varies according to the frequency of the current being measured. See page 1-9, "Product Specifications."
- If excess current is input, generated heat activates a built-in safety function that blocks normal output. If this happens, remove the input immediately (remove the sensor from the conductor being measured, or reduce the input current to zero). Wait until the sensor has had sufficient time to cool before resuming operation.
- If you continuously input a current even if it is below the maximum current value established by the maximum continuous input range, the self-heating of the sensor may cause the safety function of the instrument to activate in order to prevent damage to the instrument.
- At high ambient temperatures, the built-in safety circuit may activate at current input levels below the rated continuous maximum.
- Continuous input of current exceeding the rated maximum, or repeated activation of the safety function may result in damage to the unit.
- The probe is rated for maximum input under two conditions in addition to the input maximums shown in the Product Specifications. These are: (1) 300 A_{peak}, for non-continuous input, and (2) 500 A_{peak} at Pulse Width $\leq 30 \mu\text{s}$. (1) indicates an upper waveform response limit of 300 A_{peak}. Use the sensor at RMS current input levels that are within the rated continuous maximums. (2) indicates the upper response limit for a single input pulse. Use the sensor at levels not exceeding this value.
- Open the clamp only by using clamp lever.

1. Check that the system is safe, and that the preparations described in the preceding section have been carried out.
2. Pull the sensor opening lever so that the sensor head opens.
3. Align the sensor so that the current direction indication corresponds to the direction of current flow through the conductor to be measured, and clamp so that the conductor is in the center of the sensor aperture.

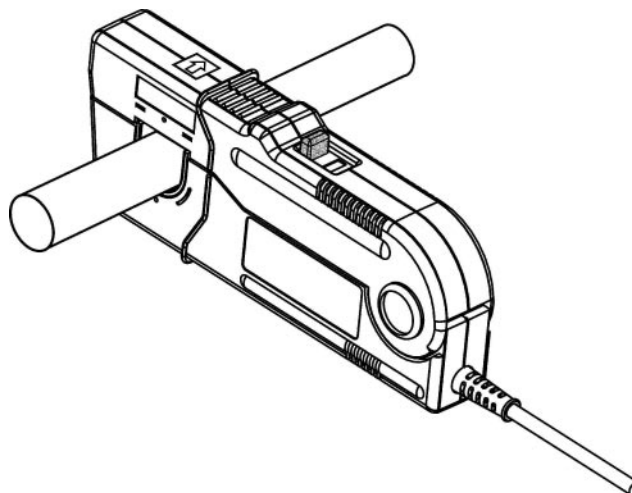

-
- Press the clamp lever on the sensor head until the **LOCK** indicator appears (and the **UNLOCK** indication disappears), and check that the opening lever is firmly locked and the clamp is securely closed.
 - It is now possible to monitor the current waveform. The output voltage rate of the 701930 is 0.01 V/A. Convert the voltage sensitivity of the waveform observation instrument to current sensitivity. For example, if the voltage sensitivity is 10 mV/DIV, the current sensitivity is 1 A/DIV.

Note

- The output of this unit is terminated internally. Use a waveform measurement instrument with an input impedance of at least 1 M Ω .
- Immediately after powering on, this unit may be subject to an appreciable offset drift due to the effect of self-heating. To counteract this, allow the unit to warm up for about 30 minutes before carrying out measurement.
- When performing continuous measurements, be aware that the offset voltage drifts depending on factors such as the ambient temperature.
- Under certain circumstances, oscillation may occur if the probe is connected to the Power Supply (Model 700938 or 701934) while the power supply is ON. In such cases, oscillation can be stopped and operation restored to normal by opening and closing the clamp with the clamp lever.
- Depending on the measured current value or its frequency, resonant sounds may be generated from the clamp. Unless there is dirt or foreign matter on the matching surfaces of the sensor head, this will have no effect on measurement.
- The reading may be affected by the position within the clamp aperture of the conductor being measured. The conductor should be in the center of the clamp aperture.
- When carrying out measurement, press the clamp lever until the **LOCK** indication appears (and the **UNLOCK** indication disappears), and check that the clamp is properly closed. If the clamp is not properly closed, accurate measurement will not be possible.
- At high frequencies, common mode noise may affect measurements taken on the high voltage side of circuits. If this occurs, reduce the frequency range of the waveform measuring instrument, or clamp onto the low-voltage side of the circuit, as appropriate.

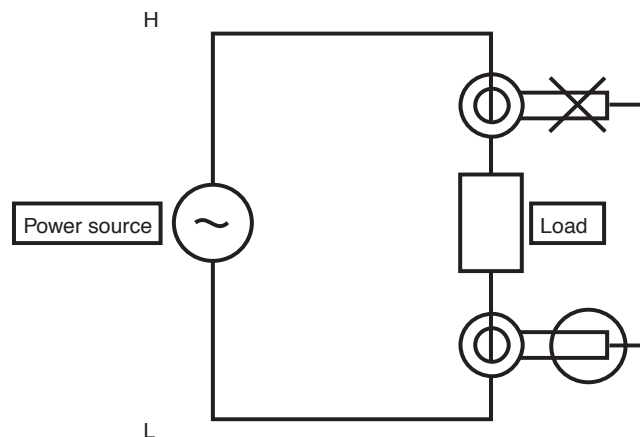

- Directly after powering ON, the demagnetizing waveform appears in the output; this is not a malfunction.
 - Accurate measurement may be impossible in locations subject to strong external magnetic fields such as transformers and high-current conductors, or in locations subject to strong external electric fields such as radio transmission equipment.
-

Specifications

Product Specifications

Accuracy is guaranteed at $23 \pm 3 \text{ }^\circ\text{C}$ ($73^\circ\text{F} \pm 5^\circ\text{F}$) after the power has been on for 30 minutes.

Band width*	DC to 10 MHz (–3 dB) (Typical characteristics shown in Page1-10, Fig.1)
Rise Time*	35 ns or less
Maximum Continuous Input Range	150 A(Derating according to frequency shown in Page1-10, Fig.2)
Maximum Peak Current Value	Non-Continuous 300 Apeak, or 500 Apeak at Pulse Width $\leq 30 \text{ }\mu\text{s}$.
Output Voltage Rate*	0.01 V/A
Amplitude Accuracy*	To 150 A: $\pm 1\%$ rdg. $\pm 1 \text{ mV}$ 150 A to 300 Apeak: $\pm 2\%$ rdg. (DC, and 45 to 66 Hz)
Noise*	Equivalent to 25 mArms or less (for 20 MHz band measuring instrument)
Insertion Impedance	(Typical characteristics shown in Page 1-10, Fig.3)
Temperature Coefficient for Sensitivity*	$\pm 2\%$ or less (within a range of 0 to 40°C or 32 to 104°F when inputting 55 Hz, 150 A)
Maximum Rated Power	5.5 VAm _{ax} (at the maximum continuous input range)
Rated Supply Voltage	$\pm 12 \text{ V} \pm 1 \text{ V}$
Operating Temperature and Humidity Range	0 to 40°C (32 to 104°F), 80% RH or less (no condensation)
Storage Temperature and Humidity Range	-10 to 50°C (14 to 122°F), 80% RH or less (no condensation)
Location for Use	Indoor, altitude up to 2000 m (6562 feet)
Effect of External Magnetic Fields	Equivalent to a maximum of 150 mA (in a DC or 60 Hz, 400 A/m magnetic field)
Maximum Ratings Voltage Between Ground	600 V CATII, 300 V CATIII (insulated conductor)
Diameter of Measurable Conductors	$\phi 20 \text{ mm}$
Recommended Calibration Period	6 months
Cable Lengths	Sensor Cable: Approx. 2 m (78.7"). Power Supply Cable: Approx. 1 m (39.4")
External Dimensions	Sensor: Approx. 176(W) \times 69(H) \times 27(D) mm. Approx. 6.93"(W) \times 2.72"(H) \times 1.06"(D) Terminator: Approx. 27(W) \times 55(H) \times 18(D) mm. Approx. 1.06"(W) \times 2.17"(H) \times 0.71"(D)
Mass	Approx. 500 g. Approx. 17.6 oz.
Accessories	Instruction manual, carrying case

* In conjunction with a waveform measuring instrument with an input impedance of $1 \text{ MW} \pm 1\%$

Applicable Standards

Safety	EN61010-2-032 Type B, Measurement category II, III (anticipated transient overvoltage 4000 V), pollution degree 2
EMC	EN61326

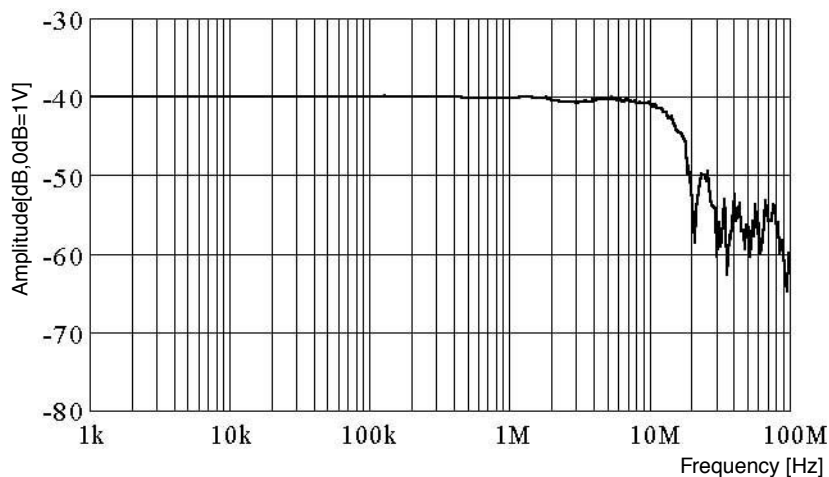

Figure 1 Frequency Characteristics(Typical Characteristics)

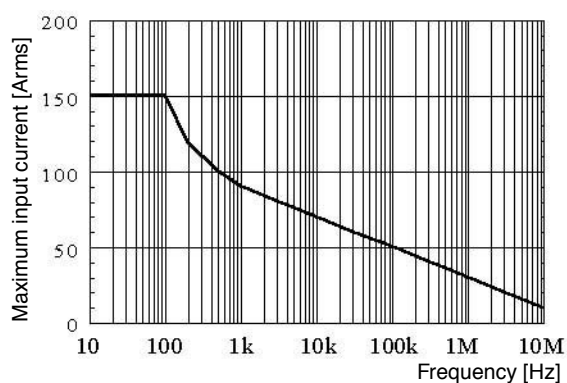

Figure 2 Derating According to Frequency

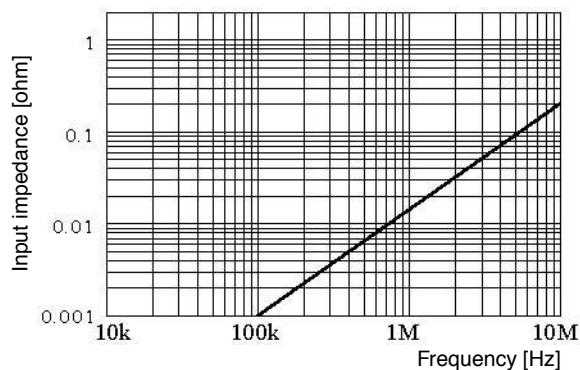

Figure 3 Insertion Impedance (Typical Characteristics)

Chapter 2 Malfunction? First, Investigate.

Corrective Action to be Taken in Case of an Abnormality

If maintenance service is required, or if the instrument still does not operate properly even after proper corrective action has been taken, contact your nearest YOKOGAWA representatives listed on the back cover of this manual.

Symptom	Possible Cause	Corrective Action
Cannot make DC measurements (or at low frequencies up to few hundred Hertz) or the amplitude is small in the given frequency region.	Power is not turned ON.	Turn ON the power.
	The measurement instrument, such as an oscilloscope, is set to AC coupling.	Set the instrument to DC coupling.
	The sensor is not locked (it is not hooked securely).	Lock the sensor.
Cannot adjust to the zero level using the zero adjustment dial.	The sensor is magnetized.	Demagnetize the sensor before adjusting the zero level.
The amplitude is small across all frequencies.	The input impedance of the measurement instrument, such as an oscilloscope, is set to 50Ω.	Set it to 1MΩ.